

# Technical Information Sheet

## Rooflight Application Guide



TIS103 November 2020

Previous issue April 2020

### Site assembled rooflight for use with a built-up profiled metal system that incorporates a 0.4mm gauge steel liner

#### Typical cross section

Stitch screws @ 450mm centres where rooflight overlaps (preferred option). For exposed sites or roof pitches less than 10° reduce centres to 300mm

Continuous run of 6mm bead or 6mm x 5mm tape, cross-linked butyl mastic sealant on the weather side of the stitch fasteners

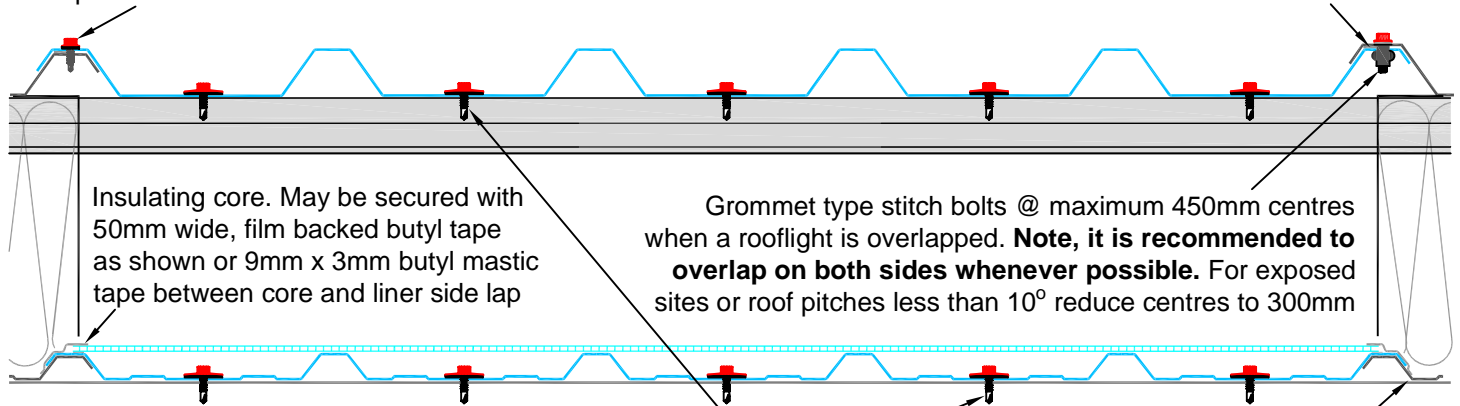

Minimum 5.5mm diameter austenitic stainless steel main fasteners that incorporate minimum 29mm diameter sealing washers @ maximum 200mm centres for outer sheets or minimum 5 fasteners per sheet width for liners. Minimum 19mm diameter sealing washers may be used with a CE36E, CEDR30E or Supasafe E sheet subject to wind loads.

Liner should overlap on both sides. Use 50mm wide, film backed butyl tape to provide an air seal

#### Typical end laps and intermediate purlins

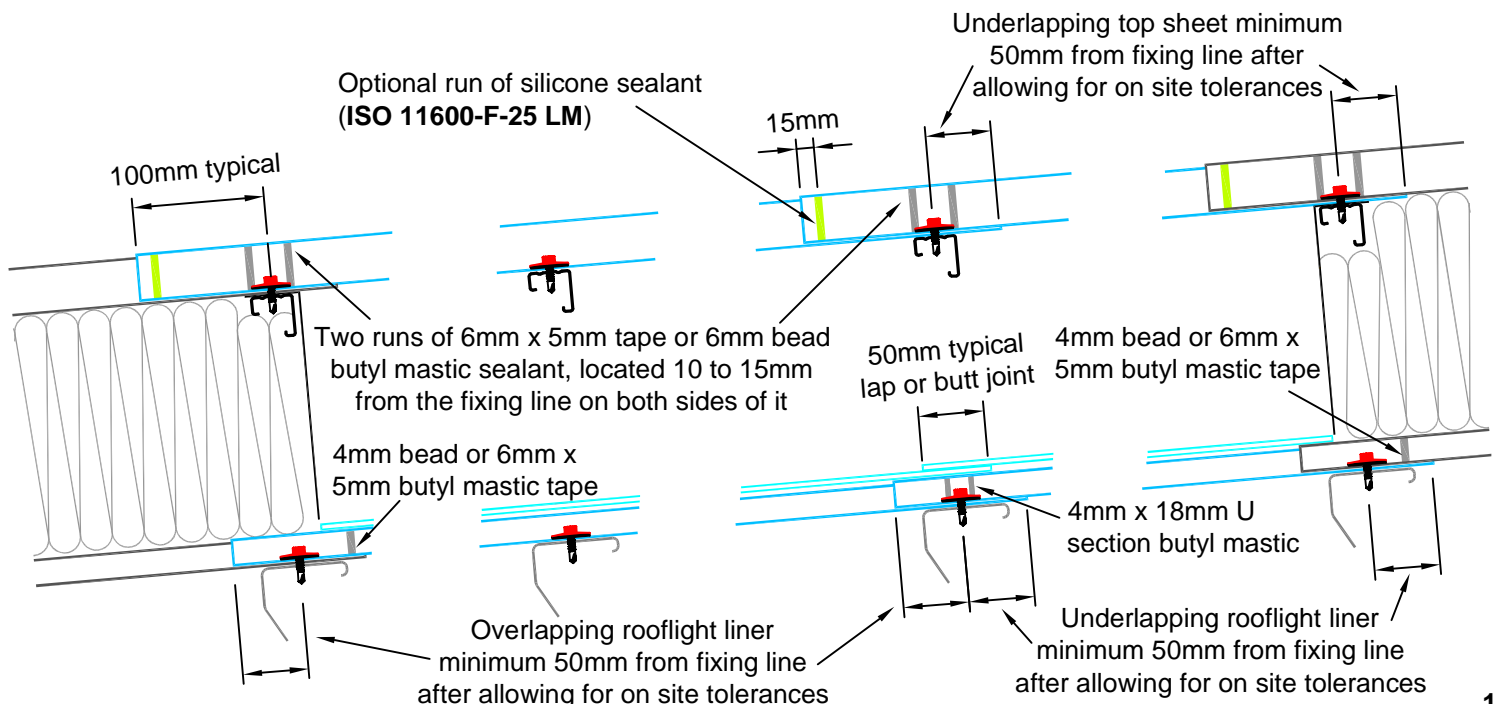

TIS103 November 2020



Recommended sheet types when lining out first

Filon outer sheet type	<sup>1</sup> Non-fragility classification to ACR[M]001 with a minimum CE24 liner	<sup>2</sup> Expected period of non-fragility	Recommended frequency of roof access	<sup>3</sup> Recommended purlin spans when using a CE24 liner
<sup>4</sup> CE18E	B	<sup>5</sup> 5 to 20 years	Infrequent	1.35m to 2.0m
<sup>4</sup> CE24E	B	25 years	Infrequent	1.35m to 2.0m
CE30E @ CEDR24E	B	25 years plus	Frequent	1.35m to 2.0m
CE36E & CEDR30E	B	25 years plus	Frequent	1.35m to 2.0m
SUPASAFE E	B	30 years	Very frequent	1.35m to 2.0m

<sup>1</sup>Roof systems that incorporate a 0.4mm gauge steel liner normally achieve a Class C non-fragile classification at the lining out stage and a minimum CE24 rooflight liner will be Class C non-fragile when fixed and sealed as recommended. A CE18 liner will be classified as fragile at the lining out stage and should not be used.

<sup>2</sup>Note that the expected non-fragility period of rooflights is affected by all components used within the roof assembly and when a specific period of non-fragility is required all components used should have the same degree of durability as the rooflights. This would typically require the use of austenitic stainless steel fasteners that are exposed and minimum Class A butyl mastic for the rooflight installation, always consult the component manufacturer or supplier.

<sup>3</sup>A higher specification liner than a CE24 will be required in the event that purlin spans are less than 1.35m or more than 2.0m. Please contact the Filon Technical Department for recommendations.

<sup>4</sup>CE18E and CE24E outer sheet types will provide a Class B non-fragile classification when used with a correctly installed minimum CE24 liner but higher specification outer sheets may be required in areas of high wind loads or snow loads.

<sup>5</sup>Minimum specification, correctly installed rooflights are rated Class B non-fragile during the construction phase, when new, and for an expected period of 5 to 20 years depending on external factors as defined in the National Association of Rooflight Manufacturers guidance document NTD03.

**Recommended sheet types when NOT lining out first**

<b>Filon outer sheet type</b>	<b><sup>1</sup>Non-fragility classification to ACR[M]001 with a minimum CE18 liner</b>	<b><sup>2</sup>Expected period of non-fragility</b>	<b>Recommended frequency of roof access</b>	<b><sup>3</sup>Recommended purlin spans when using a CE18 liner</b>
<sup>4</sup> CE24E	B	<sup>5</sup> 5 to 20 years	Infrequent	1.35m to 2.0m
CE30E & CEDR24E	B	25 years	Frequent	1.35m to 2.0m
CE36E @ CEDR30E	B	25 years plus	Frequent	1.35m to 2.0m
SUPASAFE E	B	30 years	Very frequent	1.35m to 2.0m

<sup>1</sup>Roof systems that incorporate a 0.4mm gauge steel liner normally achieve a Class B non-fragile classification once liners and outer sheets are fully installed and a minimum CE18 rooflight liner should only be used with the recommended outer sheets. A CE18E outer sheet and CE18 liner will be classified as fragile.

<sup>2</sup>Note that the expected non-fragility period of rooflights is affected by all components used within the roof assembly and when a specific period of non-fragility is required all components used should have the same degree of durability as the rooflights. This would typically require the use of austenitic stainless steel fasteners that are exposed and minimum Class A butyl mastic for the rooflight installation, always consult the component manufacturer or supplier.

<sup>3</sup>A higher specification liner than a CE18 will be required in the event that purlin spans are less than 1.35m or more than 2.0m. Please contact the Filon Technical Department for recommendations.

<sup>4</sup>CE24E outer sheet types will provide a Class B non-fragile classification when used with a correctly installed minimum CE18 liner but higher specification outer sheets may be required in areas of high wind loads or snow loads.

<sup>5</sup>Minimum specification, correctly installed rooflights are rated Class B non-fragile during the construction phase, when new, and for an expected period of 5 to 20 years depending on external factors as defined in the National Association of Rooflight Manufacturers guidance document NTD03.

**Fire performance**

Filon Grade 300: B<sub>ROOF</sub> (t4) to BS EN 13501 Part 5. SAB to BS 476 Part 3. Standard for an outer sheet.

Filon Grade 104: Class 1 to BS 476 Part 7. Standard for a liner.

Filon Grade 101: B<sub>ROOF</sub> (t4) to BS EN 13501 Part 5. SAA to BS 476 Part 3. Class 1 to BS 476 Part 7. Class 0 as defined in Building Regulations, to BS 476 Part 6. Available when a higher fire performance than is normally required in Building Regulations is specified.

For further information, please refer to Filon Technical Information Sheet TIS003.

TIS103 November 2020



### U-value W/m<sup>2</sup>K

#### Double skin

3.0. Non-compliant for a building that is not exempt from Building Regulations.

#### Triple skin

1.7 as standard, 1.3 and 1.0 are also available. For other U-value requirements please contact Filon Technical Department.

### Typical fixing specification

#### Minimum roof pitch

In accordance with *BS 5427: Code of practice for the use of profiled sheet for roof and wall cladding on buildings*, Filon rooflights are suitable for a finished roof pitch of at least 4° (5.5° design pitch). For lower roof pitch solutions, please contact Filon Technical Department.

#### Liner main fasteners

The Filon liners should be secured to purlins with minimum 5 fasteners per sheet width that are located in the profile troughs. The fasteners should be minimum 5.5mm diameter, self drill/tap screws that incorporate minimum 29mm diameter sealing washers. Minimum 19mm diameter sealing washers may be used with a Filon CE36, CEDR30 or Supasafe liner.

#### Liner end laps

Liner end laps should be located directly above a purlin and the edges of any sheet in the joint should be minimum 50mm from the fixing line. The end lap joints should be sealed with a continuous run of 4mm bead or 6mm x 5mm tape, cross-linked butyl mastic sealant.

Note that for rooflight to rooflight liner end laps it is recommended that they should be sealed with a continuous run of 4mm x 18mm U section butyl mastic centred over the fixing line, applied before the main fasteners are installed.

#### Liner side laps

The Filon liners should be side lapped over the adjacent metal liners on both sides and the joints sealed with a 50mm wide, cross-linked, film backed butyl mastic tape that is located along the full length of the joints to provide an air seal.

#### Core panel

The core panel should be placed onto the Filon liner and the sides of the panel may be secured with the same run of 50mm wide tape used for the liner, subject to profile depth, and applied in the same operation. Alternatively, a continuous run of 9mm x 3mm cross-linked butyl mastic tape between the core panel and the lapping profile crowns of the liner may be used. The core panels may be end lapped at intermediate purlin positions. The lap joint should be typically 50mm long and the use of end lap sealants is not required. Alternatively the core panels may be butt jointed. The spacer system brackets may be located either side of the rooflight area to avoid fouling with the core panel. The core panel may also be notched around a spacer bracket in the event that it is preferable to locate it within the rooflight area. Note, consult the spacer system manufacturer for their recommendations.

#### Outer sheet main fasteners

The Filon outer sheets should be secured to the spacer system with minimum 5.5mm diameter, austenitic stainless steel self drill/tap screws that incorporate minimum 29mm diameter sealing washers, typically coloured poppy red, at maximum 200mm centres across the sheets located in the profile troughs. Subject to wind loads, minimum 19mm diameter sealing washers may be used with a Filon CE36E, CEDR30E or Supasafe E outer sheet.

#### Outer sheet end laps

The end laps of the Filon outer sheets should be located directly over the spacer bar and the edges of any sheet in the joint should be minimum 50mm from the fixing line, typical end lap length is 150mm. The end lap joints should be sealed with two continuous runs of 6mm x 5mm tape or 6mm bead cross-linked butyl mastic sealant. The sealant should be located within 10mm to 15mm of the fixing line on either side of it. An optional run of gun applied silicone to classification ISO 11600-F-25 LM, may be applied 15mm from the leading edge of the overlapping sheet within the joint to provide a supplementary seal and prevent dirt ingress. Note that rooflight to rooflight external skin sheet end laps may be fixed and sealed as above.

TIS103 October 2020



**Typical fixing specification continued**

**Outer sheet side laps**

The side lap joints should be stitched at maximum 450mm centres with standard stitch screws where the rooflight overlaps the metal sheet. If the rooflight should have to underlap the adjacent metal sheet or lap to another rooflight, purpose made rooflight stitch fasteners such as expanding rubber grommet bolts should be used. Note that it is preferable to overlap the metal sheets on both sides whenever possible. On exposed sites or roof pitches below 10° reduce stitch centres to 300mm. The side lap joints should be sealed with a single continuous run of 6mm x 5mm tape or 6mm bead cross-linked butyl mastic sealant located on the weather side of the stitch fasteners.

**Notes**



Filon Products Limited  
Unit 3, Ring Road, Zone 2, Burntwood Business Park  
Burntwood, Staffordshire WS7 3JQ, England

Tel: +44 (0)1543 687300 Fax: +44 (0)1543 687303  
Email: sales@filon.co.uk Website: www.filon.co.uk

**FILON is a trademark of Filon Products Ltd.**

Information and recommendations contained in this publication are given in good faith without warranty or guarantee. Because we are constantly seeking to improve our products we reserve the right to change specifications at any time. No liability can be accepted for any claims, losses or demands arising from the contents of this publication. This statement does not affect any statutory rights which cannot be excluded by agreement

